

# HUNTING FOR NEW PHYSICS:

Alakabha Datta

University of Mississippi

November 2 , 2007

# OUTLINE

- General Introduction
- Aim of Particle Physics, Particle Types
- Language of Particle Physics- Feynman Diagrams, Matter-Antimatter Puzzle
  
- Standard Model (SM) and its unsolved problems
- Suggest SM is not a complete theory. Search goes on for the complete theory which we call **NEW PHYSICS**
- How do we search for **NEW PHYSICS**

# Aim of Particle Physics

- Aim: To answer eternal questions people have long asked:
- What is the Universe made of? How did it begin? What is the future?
- What holds it together?
  
- Particle Physics aims to understand the fundamental building blocks of matter and their interactions
- Matter that make up the Universe today and matter that existed in the past
  
- Particle Physics plays a very important role in understanding the evolution of our Universe from its birth(Big Bang) to its present time.



TIME BEGINS

ONE SECOND

PRESENT DAY

Time	$10^{-43}$ sec.	$10^{-32}$ sec.	$10^{-6}$ sec.	3 min.	300,000 yrs.	1 billion yrs.	15 billion yrs.
Temperature		$10^{27}$ °C	$10^{13}$ °C	$10^8$ °C	$10,000$ °C	-200° C	-270° C

**1** The cosmos goes through a superfast "inflation," expanding from the size of an atom to that of a grapefruit in a tiny fraction of a second

**2** Post-inflation, the universe is a seething, hot soup of electrons, quarks and other particles

**3** A rapidly cooling cosmos permits quarks to clump into protons and neutrons

**4** Still too hot to form into atoms, charged electrons and protons prevent light from shining; the universe is a superhot fog

**5** Electrons combine with protons and neutrons to form atoms, mostly hydrogen and helium. Light can finally shine

**6** Gravity makes hydrogen and helium gas coalesce to form the giant clouds that will become galaxies; smaller clumps of gas collapse to form the first stars

**7** As galaxies cluster together under gravity, the first stars die and spew heavy elements into space; these will eventually form into new stars and planets

NOTE: The numbers in cosmology are so great and the numbers in subatomic physics are so small that it is often necessary to express them in exponential form. Ten multiplied by itself, or 100, is written as  $10^2$ . One thousand is written as  $10^3$ . Similarly, one-tenth is  $10^{-1}$ , and one-hundredth is  $10^{-2}$ .

Source: *The Birth of the Universe*; *The Kingfisher Young People's Book of Space*

TIME Graphic by Ed Gabel

# Particle Types

- Particles come in two types: Bosons and Fermions

## BOSONS

force carriers  
spin = 0, 1, 2, ...

Unified Electroweak spin = 1

Name	Mass GeV/c <sup>2</sup>	Electric charge
$\gamma$ photon	0	0
$W^-$	80.4	-1
$W^+$	80.4	+1
$Z^0$	91.187	0

Strong (color) spin = 1

Name	Mass GeV/c <sup>2</sup>	Electric charge
$g$ gluon	0	0

# Particle Types- Fermions

## FERMIONS

matter constituents  
spin =  $1/2, 3/2, 5/2, \dots$

### Leptons spin = $1/2$

Flavor	Mass GeV/c <sup>2</sup>	Electric charge
$\nu_e$ electron neutrino	$<1 \times 10^{-8}$	0
<b>e</b> electron	0.000511	-1
$\nu_\mu$ muon neutrino	$<0.0002$	0
<b><math>\mu</math></b> muon	0.106	-1
$\nu_\tau$ tau neutrino	$<0.02$	0
<b><math>\tau</math></b> tau	1.7771	-1

### Quarks spin = $1/2$

Flavor	Approx. Mass GeV/c <sup>2</sup>	Electric charge
<b>u</b> up	0.003	2/3
<b>d</b> down	0.006	-1/3
<b>c</b> charm	1.3	2/3
<b>s</b> strange	0.1	-1/3
<b>t</b> top	175	2/3
<b>b</b> bottom	4.3	-1/3

# Particle Types

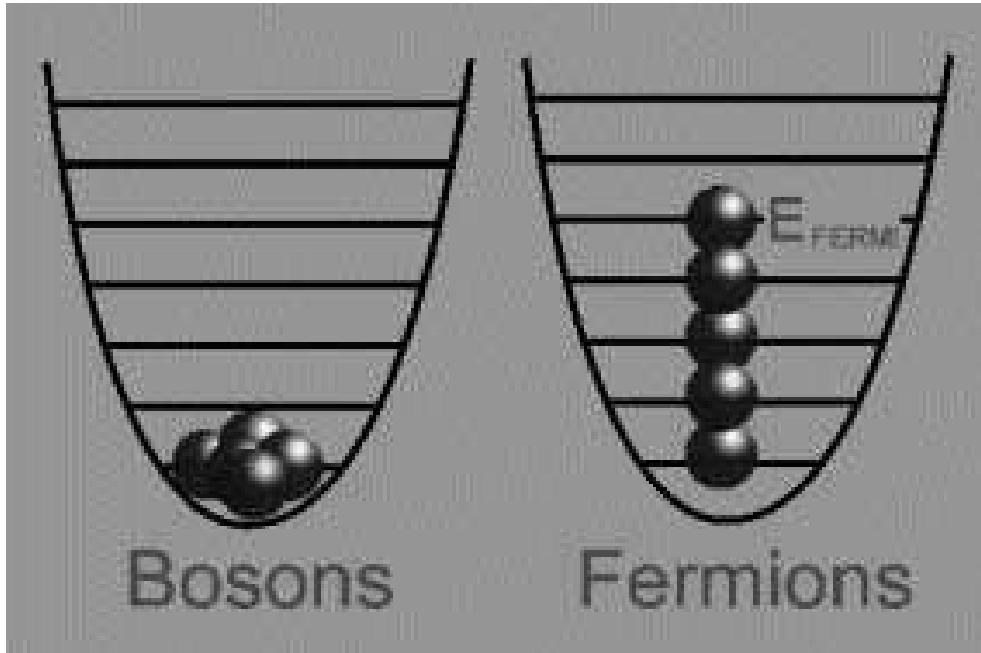

- A collection of bosons and fermions will fill up a given set of energy levels differently. Bosons satisfy Bose-Einstein Statistics. Fermions satisfy the Fermi-Dirac Statistics.
- Bosons have integral spin and are responsible for forces between particles
- Spin: Intrinsic angular momentum of a particle- intrinsic property just like mass and charge

# Language of PP- Feynman Diagrams

- Particles and their interactions are described by Feynman Diagrams

## *Feynman Diagrams*

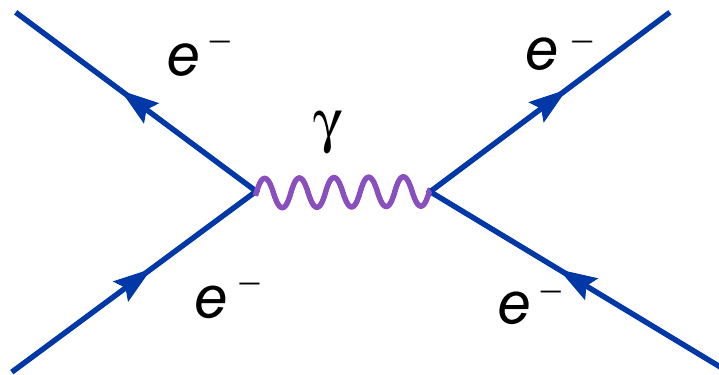

*Coulomb Force*

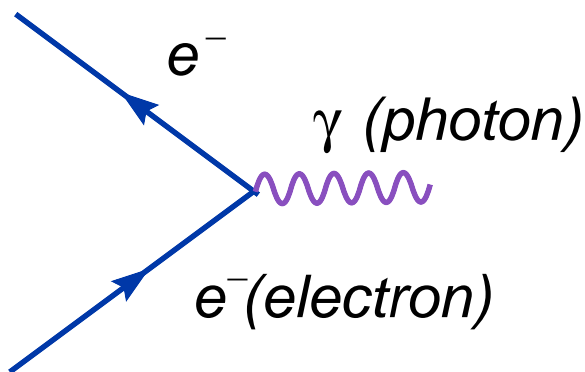

*Electron in EM Field*

$$F = \frac{K|e||e|}{r^2} \text{ (Coulomb)} \quad F = eE .$$

# Antiparticle- Creation and Annihilation

- All particles have antiparticles. Antiparticles have the same mass as the particle but opposite quantum numbers like charge

E.g. : The antiparticle of electron ( $e^-$ ) is the positron ( $e^+$ ). If a particle is  $P$  the antiparticle is often represented by  $\bar{P}$ .

Particle and antiparticle can annihilate into energy. Energy can be converted to particle antiparticle pair(  $E = mc^2$ )

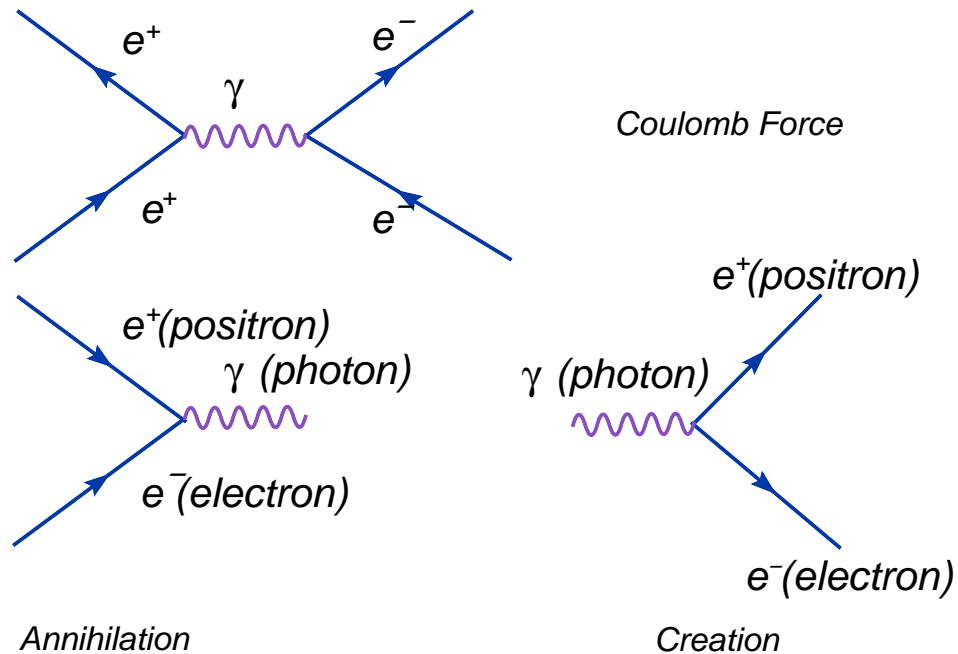

# Particle Accelerators

- Particle Accelerators use energy from particle- antiparticle annihilation to create new particles that existed in the Universe in the past.
- In the early hot( high energy ) Universe many particles were created that are no longer produced today. These particles have decayed to the particles that make up the Universe today.
- Particle Accelerators create conditions similar to that in the early Universe and can create particles that existed in the past.

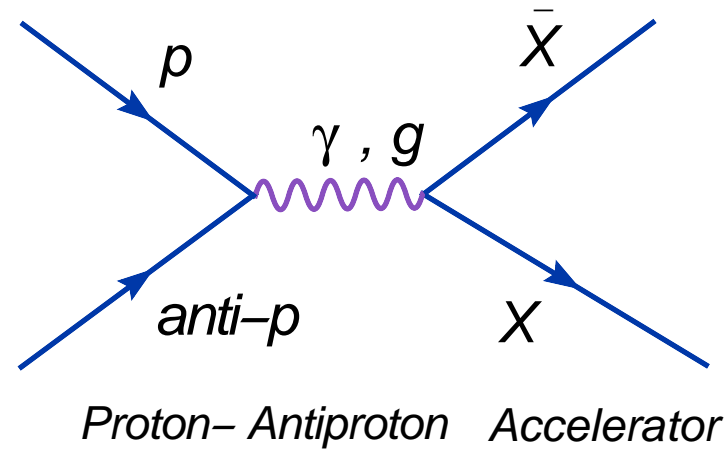
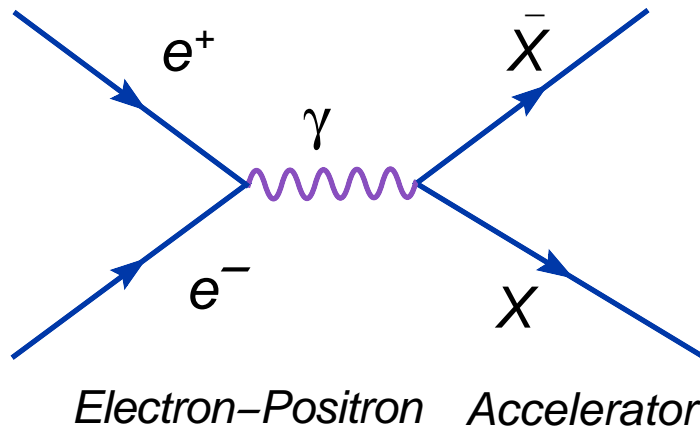

# Summary and a Puzzle

- Particles are Bosons ( spin 0,1,2) or Fermions ( spin 1/2)
- Fermions make up matter while Bosons are the force carriers
- Particles have Antiparticles. Energy can create Particle-Antiparticle pair and the pair can annihilate into energy.
- Puzzle: Universe was created with a Big Bang: Matter was created out of Energy of the Bang.

Big Bang should create equal number of particles and antiparticles. The Universe is matter dominated. Where are the antiparticles? Why did the antiparticles not annihilate with matter into pure energy.

# The Standard Model

- Eternal Questions people have long asked:
- What is the world made of?
- What holds it together?
- Answer today is provided by the Standard Model (SM) of particle physics:

$$SM \equiv \begin{pmatrix} u \\ d \end{pmatrix} \text{ Quarks} \quad \begin{pmatrix} \nu_e \\ e \end{pmatrix} \text{ Leptons} \quad \text{spin } \frac{1}{2} \text{ Matter Particles}$$

Gauge Bosons ( spin 1):  $W^\pm, Z^0$   $g(\text{gluons})$   $\gamma(\text{photon})$  -Forces

Higgs ( spin 0)  $H^0$

# Forces

- There are four fundamental forces
- Electromagnetic Force: Force carrier is the photon  $\gamma$ .
- Strong Nuclear Force: Force carrier is the gluon  $g$ .
- Weak Nuclear Force: Force carriers are the  $W^\pm$  and  $Z$  bosons.
- Gravitational Force: Force carrier is called the graviton.
- The Standard Model is a theory of only 3 forces, the strong and weak nuclear forces and Electromagnetism. Gravity is not included.

# Matter: Quark and Lepton Flavor

$SM \equiv \begin{pmatrix} u \\ d \end{pmatrix}$  Quarks  $\begin{pmatrix} \nu_e \\ e \end{pmatrix}$  Leptons spin  $\frac{1}{2}$  Matter Particles

- Lepton Flavor: electron (e) and the electron type neutrino ( $\nu_e$ ) can exist as free particles.

$$Q(e) = -|e| \quad Q(\nu_e) = 0$$

- Quark Flavor: up quark (u) and down quark (d) do not exist as free particles but are bound inside hadrons.

Quarks carry the quantum number **color** (R, B and G) and experience the strong nuclear force that bind them in hadrons. Leptons do not have color and do not experience the strong force.

$$Q(u) = \frac{2}{3}|e| \quad Q(d) = -\frac{1}{3}|e|$$

# Bound States: Baryons and Mesons

- Baryons are  $qqq$  bound states: e.g. proton, neutron..

*PROTON( uud State)*

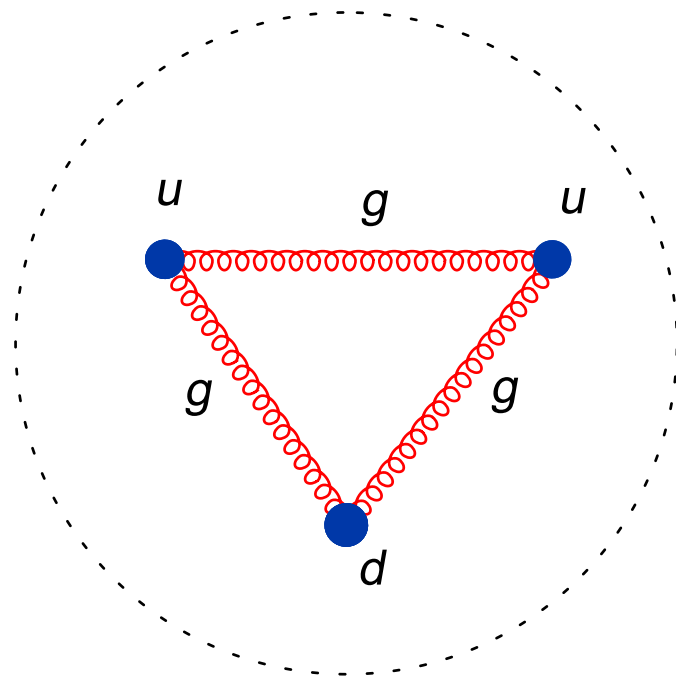

*NEUTRON(udd State)*

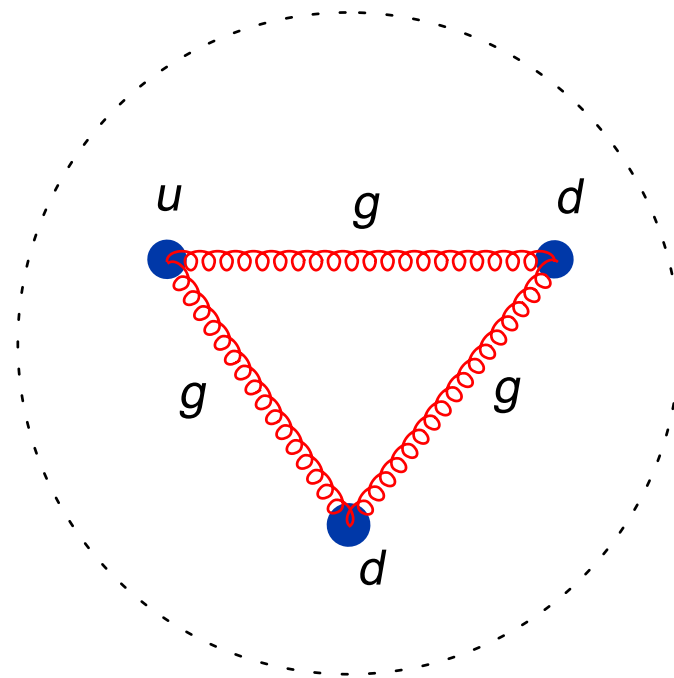

- Quarks inside the baryons are held together by the **strong force** which arise from the exchange of **gluons**

# Bound States: Baryons and Mesons

- Mesons are  $q\bar{q}$  bound states: e.g. pions.

*CHARGED PION( u anti-d State)*

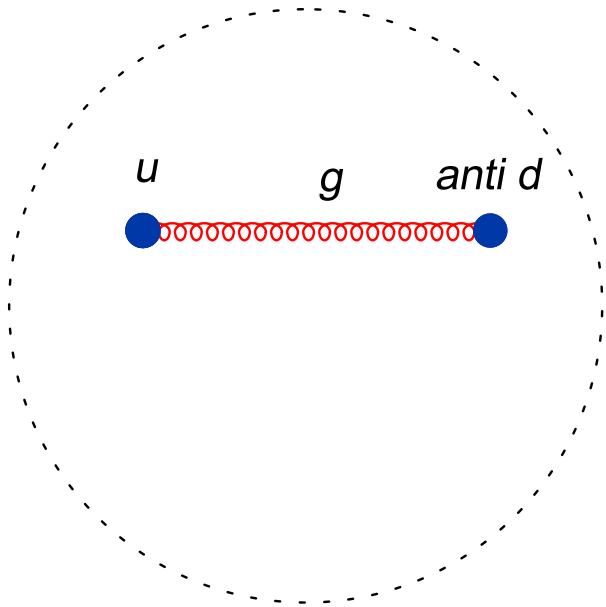

*NEUTRAL PION(u anti u State)*

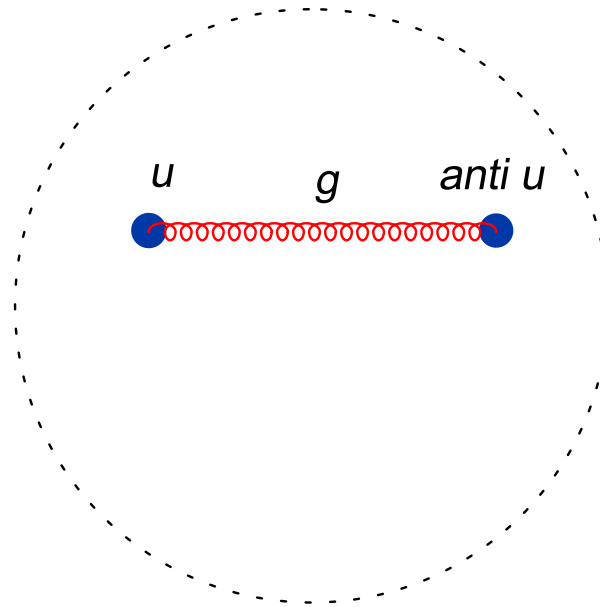

- Hadrons= Baryons + Mesons

# Bound States: Nucleus

Nucleus is a bound states of proton and neutron held together by the **strong nuclear force**.

Inter nucleon force is also a color force.

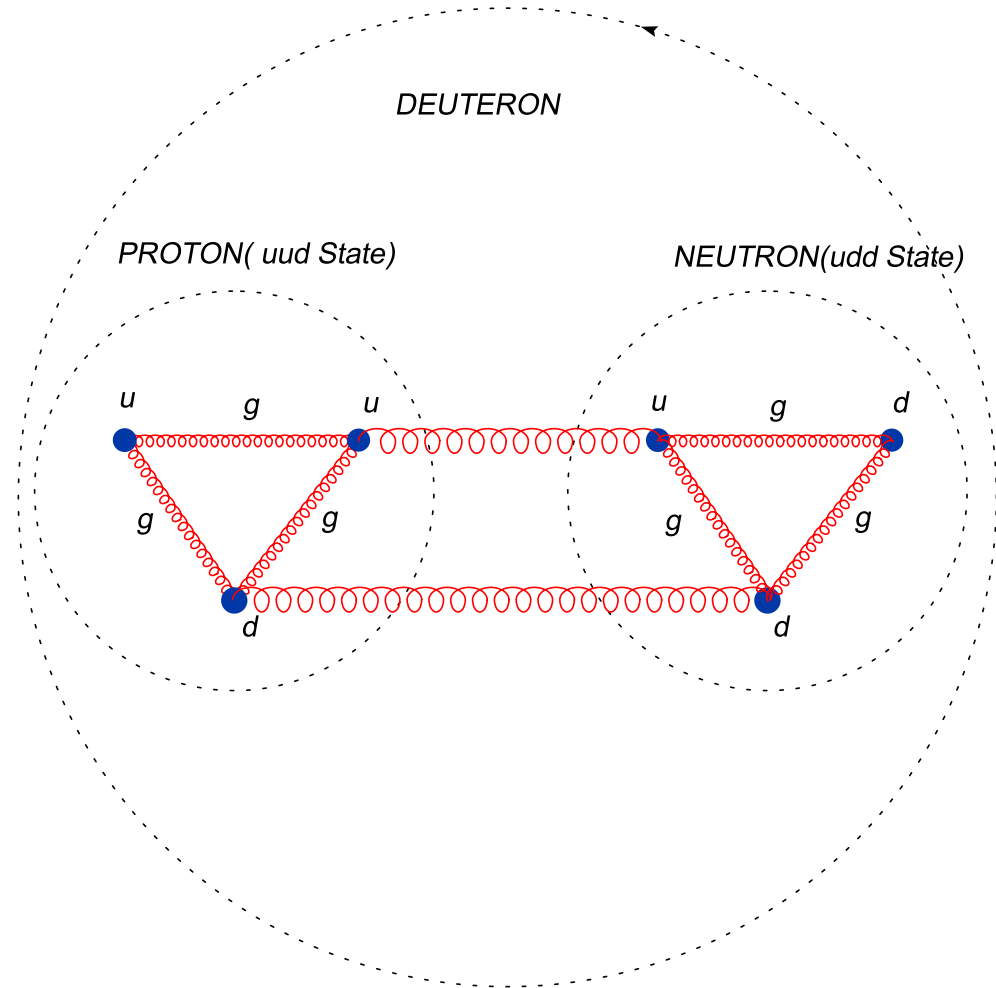

# Bound States: Atoms

- Atom is a bound states of nucleus and electrons held together by the electromagnetic force.

- Atom  $\sim 10^{-10}$  m
- Nucleus  $\sim 10^{-14}$  m
- p,n  $\sim 10^{-15}$  m
- quark, electron  $\sim 10^{-18}$  m

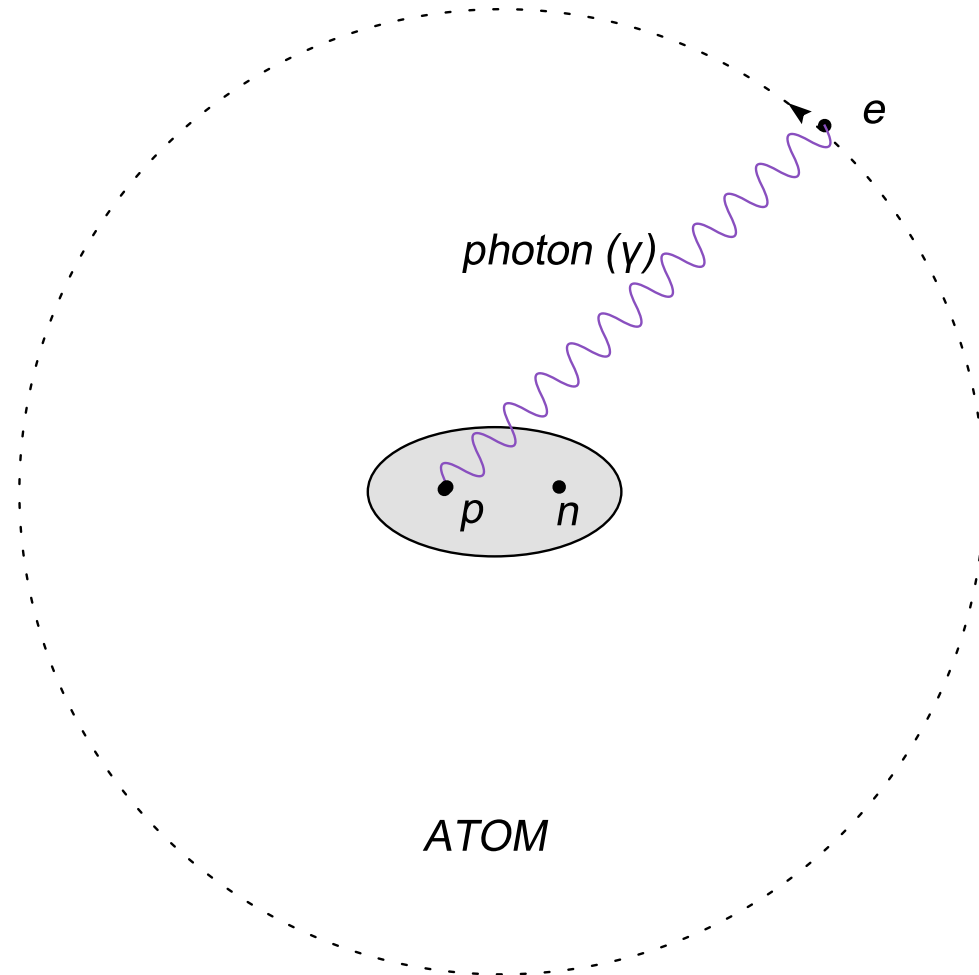

# Weak Interactions

- Quarks and Leptons also experience the the weak nuclear force

- Two kinds of Weak Interactions:

Charged Current: through the exchange of  $W^\pm$

$$SM \equiv \begin{pmatrix} u \\ d \end{pmatrix} \quad \begin{pmatrix} \nu_e \\ e \end{pmatrix} \quad \text{spin } \frac{1}{2}$$

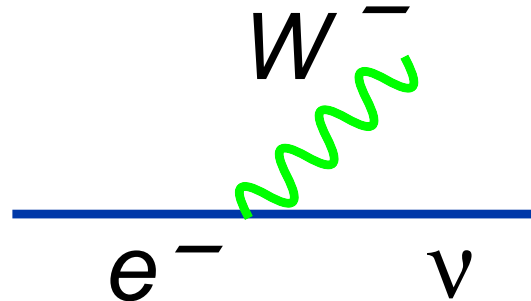
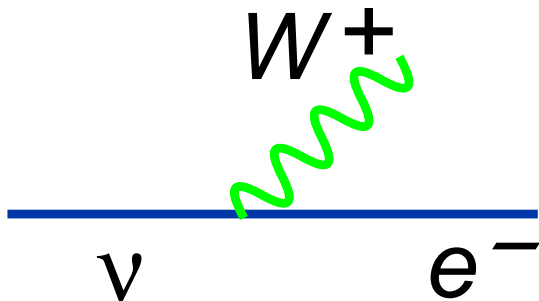
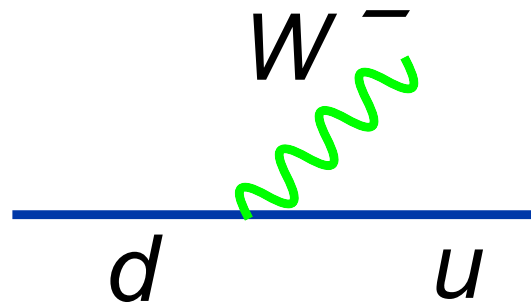
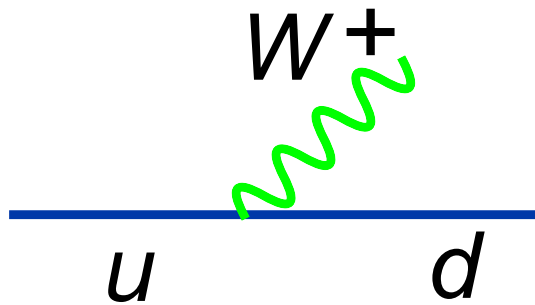

# Beta Decay

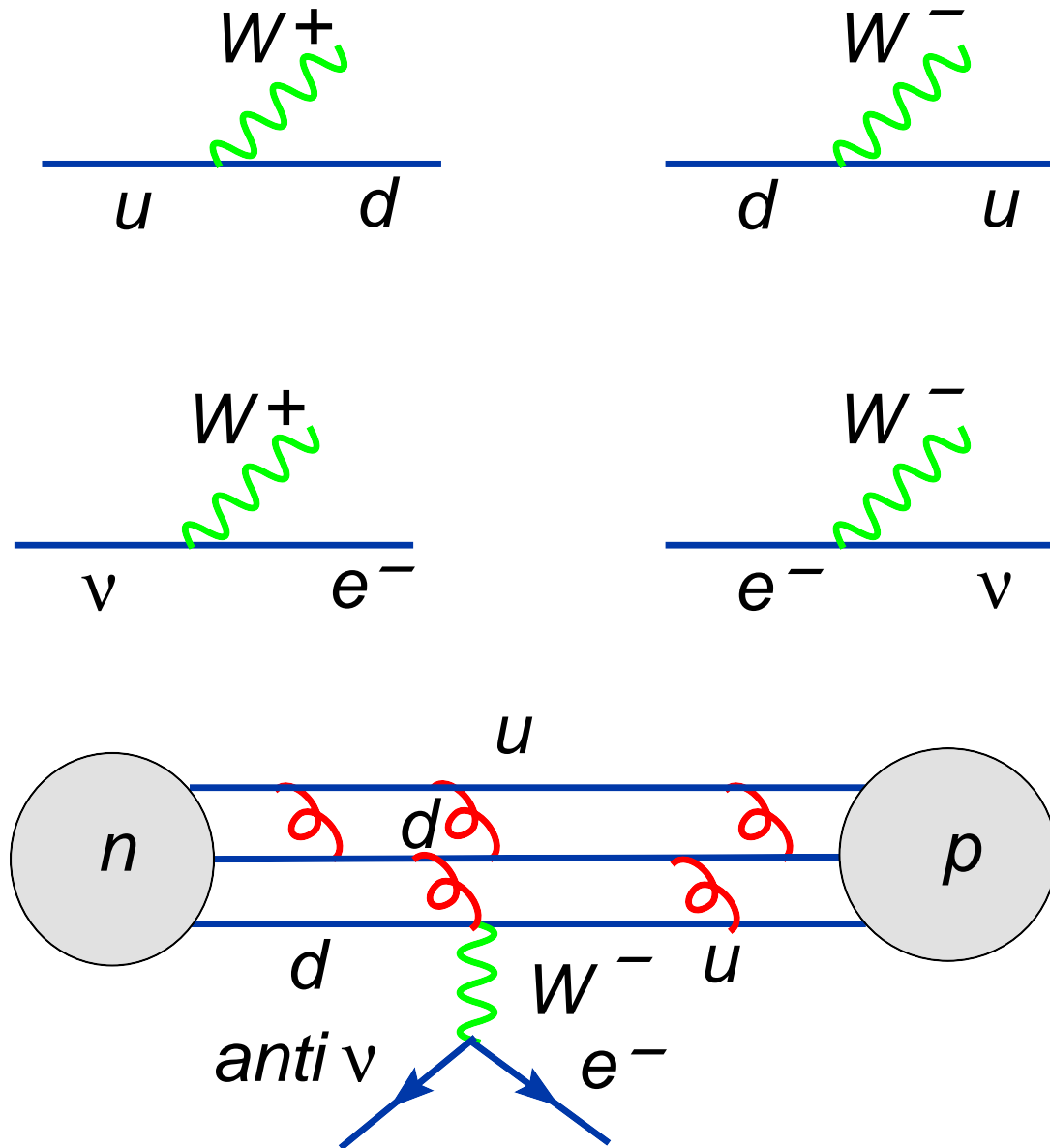

$n \rightarrow pe^- \bar{\nu}$  : beta decay

# Neutral Current Interactions

- Neutral Current Interactions are mediated through the exchange of  $Z^0$   
 *$e - \nu$  and  $p - \nu$  scattering*

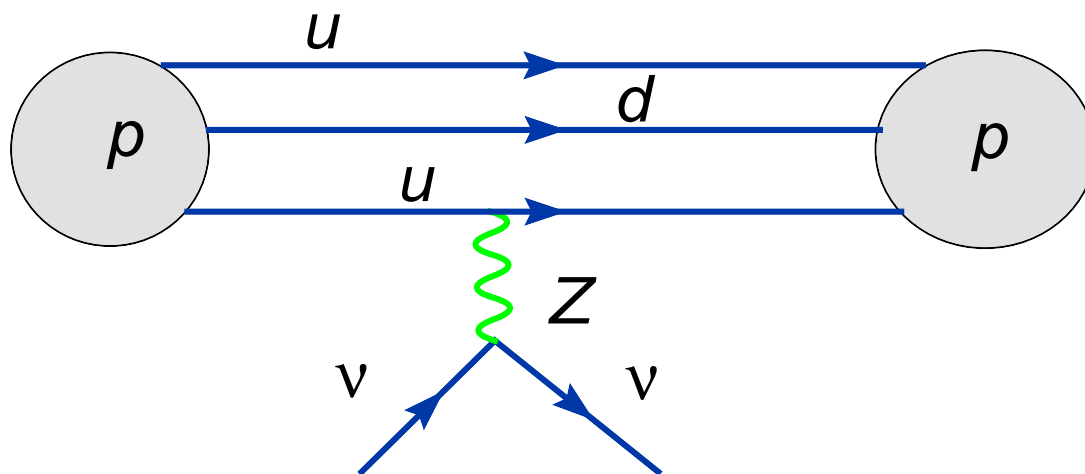
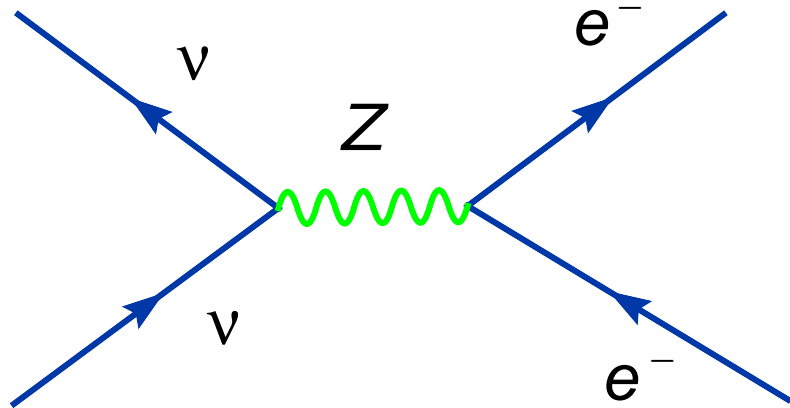

# Weak Interactions are Different

- The weak interactions are very weak- weaker than the strong and the electromagnetic force.
- The force carriers  $W^\pm$  and  $Z$  bosons are massive with masses about 100 times the mass of the proton. The carriers of the strong ( gluon) and electromagnetic force( photon) are massless.
- The weak force violate several symmetries like Parity (P), Charge Conjugation(C) and CP.

The force carriers  $W^\pm$  and  $Z$  bosons get masses by interacting with a new particle called the Higgs boson. The Higgs boson has not been discovered yet.

- Puzzle: Why are the Weak Interactions different

# The Higgs ( $m_H < 1 \text{ TeV}$ )

Quarks and Leptons as well as the weak gauge bosons  $W^\pm$  and  $Z^0$  get masses by interacting with the Higgs boson

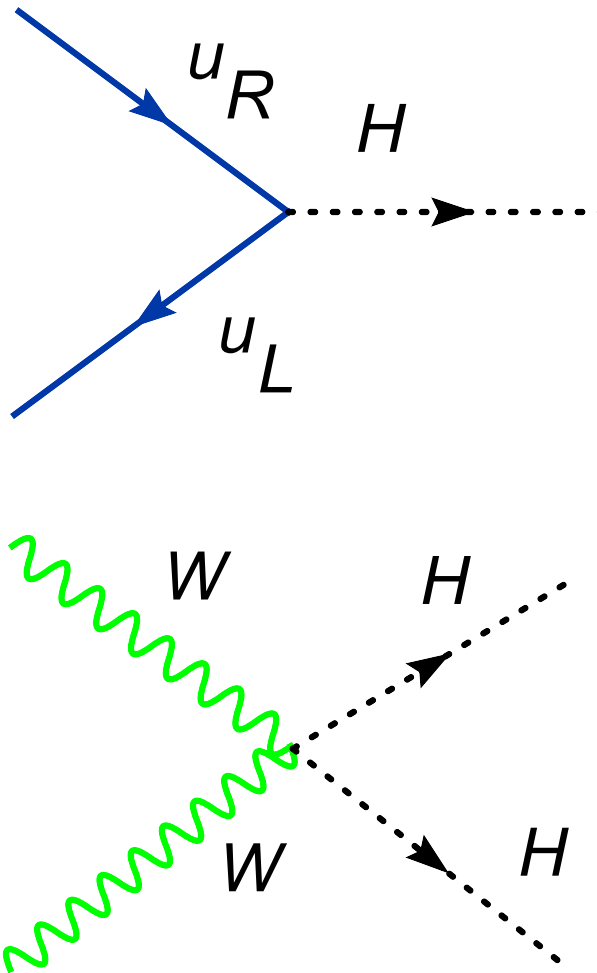

In SM the neutrino remains massless because there is no  $\nu_R$

Higgs is neutral and has no strong or EM interactions

gluons and photons are massless

# The Higgs Mechanism

- We are aware of phase change- for example steam to water to ice.
- When the universe was very hot at a temperature equivalent to 100 GeV (  $1 \text{ eV} \equiv 25 \text{ degrees C}$ ) there was a phase change when the Higgs,  $W$ ,  $Z$ , the quarks and leptons went from being massless to having masses.

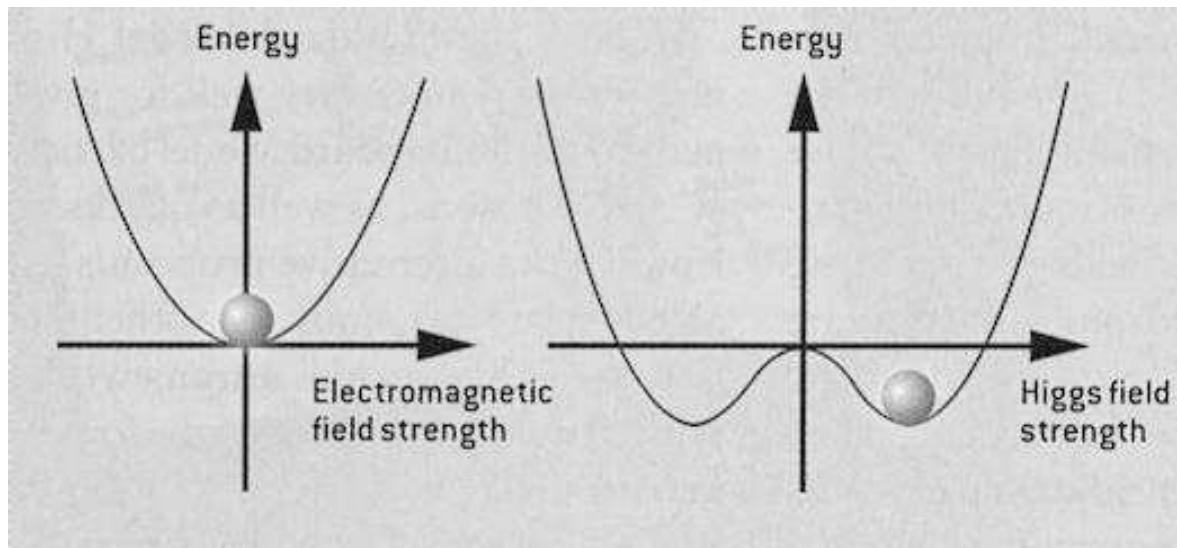

- During the phase transformation the symmetry between the weak and the electromagnetic interactions was broken making the two forces very different. This is known as electroweak symmetry breaking.

# SM Problems: The Particle Masses

- $m_e \sim 0.5 \text{ MeV}/c^2$      $m_u \sim 5 \text{ MeV}/c^2$      $m_d \sim 10 \text{ MeV}/c^2$      $m_\nu = 0$
- $m_W \sim 80 \text{ GeV}/c^2$      $m_Z \sim 90 \text{ GeV}/c^2$     ( $m_p \sim \text{GeV}/c^2$ ) (MeV=10<sup>6</sup> eV, GeV= 10<sup>9</sup> eV)
- Puzzle: Higgs boson interaction should result in similar masses for all particle i.e  $m_u \sim m_d \sim m_e \sim m_W \sim m_Z$

# Higgs mass problem

Higgs mass problem:  $m_H < 1$  TeV ( trillion electron volt which is about 1000 times proton mass) from probability conservation( Unitarity)

Quantum correction to Higgs mass

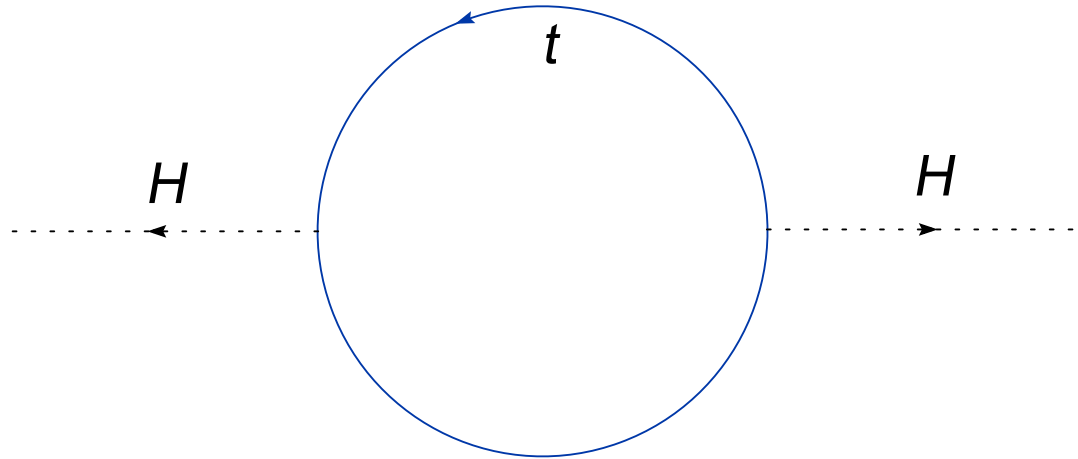

$$m_H^2 = (m_H^2)_{classical} - \Lambda^2 \sim TeV^2 \quad \Lambda \sim TeV \text{ (Energy scale up to which SM is valid)}$$

If  $m_H < 1$  TeV then natural value of  $\Lambda \sim TeV$ . New Physics will be revealed at Energy of about a TeV

- However  $\Lambda$  may be large. But how large?

# Hierarchy Problem

- The SM does not include gravity and so SM will not be valid when gravity effects are important
- For macroscopic objects like stars, planets, humans.. gravity is important but for tiny microscopic particles gravity becomes important only at very high energies or short distances.
- The energy at which gravity becomes important for fundamental particles is known as the Planck scale.  $M_{Planck} = 10^{19}$  GeV or 10 million trillion times the proton mass
- If the SM is valid till  $M_{Planck}$  then why is the Higgs mass and other particle masses so much smaller.

$$\frac{m_H}{M_{Planck}} = 10^{-16} - \text{Hierarchy Problem}$$

$$m_H^2 = (m_H^2)_{classical} - M_{Planck}^2 \sim TeV^2$$

# Things get more Complicated...

- There are three generations of quarks and leptons

$$I^{st} Gen \equiv \begin{pmatrix} u(5MeV) \\ d(10MeV) \end{pmatrix} \quad \begin{pmatrix} \nu_e(0?) \\ e(0.5MeV) \end{pmatrix} \quad \text{spin } \frac{1}{2}$$

$$II^{nd} Gen \equiv \begin{pmatrix} c(\text{charm}, 1.5GeV) \\ s(\text{strange}, 0.2GeV) \end{pmatrix} \quad \begin{pmatrix} \nu_\mu(0?) \\ \mu(\text{muon}, 0.105GeV) \end{pmatrix} \quad \text{spin } \frac{1}{2}$$

$$III^{rd} Gen \equiv \begin{pmatrix} t(\text{top}, \mathbf{175GeV}) \\ b(\text{bottom}, 5GeV) \end{pmatrix} \quad \begin{pmatrix} \nu_\tau(0?) \\ \tau(\text{tau}, 1.78GeV) \end{pmatrix} \quad \text{spin } \frac{1}{2}$$

- $M_{III} > M_{II} > M_I$

$m_t \sim 175 \text{ GeV}$      $m_t \sim m_W \sim m_Z$ - the only natural quark mass

- Puzzle: It appears that only the third family is “normal” the others are abnormal

# SM-Summary

## FERMIONS

matter constituents  
spin = 1/2, 3/2, 5/2, ...

### Leptons spin = 1/2

Flavor	Mass GeV/c <sup>2</sup>	Electric charge
$\nu_e$ electron neutrino	$<1 \times 10^{-8}$	0
$e$ electron	0.000511	-1
$\nu_\mu$ muon neutrino	$<0.0002$	0
$\mu$ muon	0.106	-1
$\nu_\tau$ tau neutrino	$<0.02$	0
$\tau$ tau	1.7771	-1

### Quarks spin = 1/2

Flavor	Approx. Mass GeV/c <sup>2</sup>	Electric charge
$u$ up	0.003	2/3
$d$ down	0.006	-1/3
$c$ charm	1.3	2/3
$s$ strange	0.1	-1/3
$t$ top	175	2/3
$b$ bottom	4.3	-1/3

# Quark Mixing

The quark generations mix- they talk to each other:

$$6 \text{ flavors } \quad 3 \text{ families } \sim \begin{pmatrix} u & c & t \\ d & s & b \end{pmatrix}$$

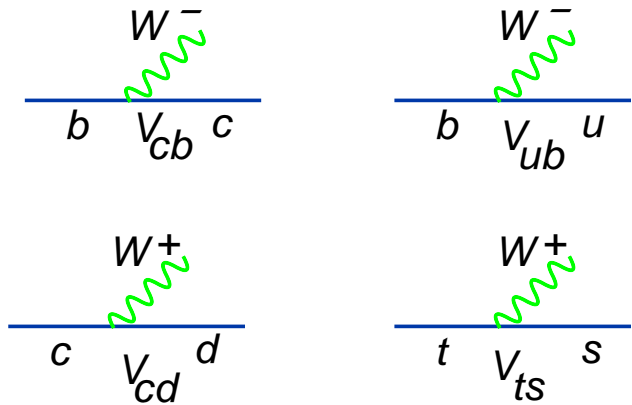

9 possible couplings from transition between up-type (u,c,t) and down-type(d,s,b) quarks :

$$V_{CKM} = \begin{pmatrix} V_{ud} & V_{us} & V_{ub} \\ V_{cd} & V_{cs} & V_{cb} \\ V_{td} & V_{ts} & V_{tb} \end{pmatrix}$$

$$V_{CKM}^\dagger V_{CKM} = 1 \quad V_{CKM} \text{ is a Unitary matrix.}$$

# Lepton Mixing

SM: There is no mixing in the lepton sector as  $m_\nu = 0$  because there is no  $\nu_R$ .

The weak interactions couple only to  $\nu_L$  and the lepton mixing can be rotated away. We now know neutrinos have masses and there will be mixing in the lepton sector also.

Deviations from the Standard Model!!!

# Decays of Mesons, Baryons

Because of Mixing heavy Mesons and Baryons Decay to lighter Mesons and Baryons

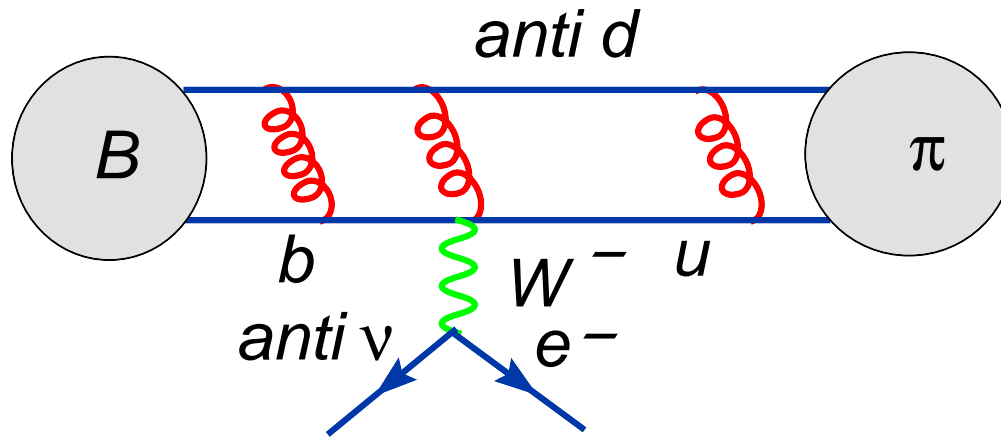

$$B \rightarrow \pi e \text{ anti } \nu$$

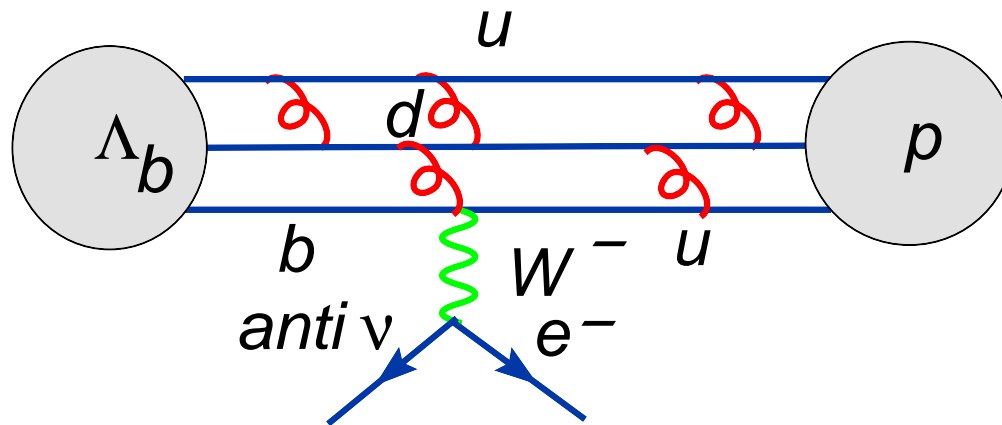

$$\Lambda_b^- \rightarrow p e \text{ anti } \nu$$

# Structure of the CKM

In the SM, CP violation is due to a complex phase in the CKM matrix:

$$V_{CKM} \simeq \begin{pmatrix} 1 - \frac{1}{2}\lambda^2 & \lambda & A\lambda^3(\rho - i\eta) \\ -\lambda(1 + iA^2\lambda^4\eta) & 1 - \frac{1}{2}\lambda^2 & A\lambda^2 \\ A\lambda^3(1 - \rho - i\eta) & -A\lambda^2 & 1 \end{pmatrix}$$

where  $\lambda = 0.22$ .

Strong hierarchy:  $I - II \sim \lambda \sim 20\%$      $II - III \sim \lambda^2 \sim 4\%$   
 $I - III \sim \lambda^3 \sim 1\%$

Unitarity Triangle:

$$V_{CKM} \simeq \begin{pmatrix} |V_{ud}| & |V_{us}| & |V_{ub}|e^{-i\gamma} \\ |V_{cd}| & |V_{cs}| & |V_{cb}| \\ |V_{td}|e^{-i\beta} & |V_{ts}| & |V_{tb}| \end{pmatrix}$$

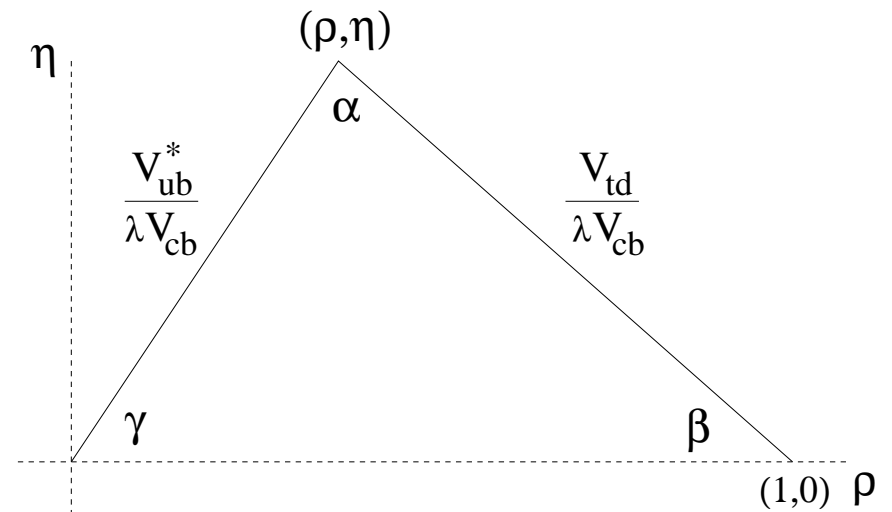

# Structure of the CKM Matrix

The elements of the CKM matrix are being/will be measured precisely to test the Standard Model at present and future Flavor Physics factories.

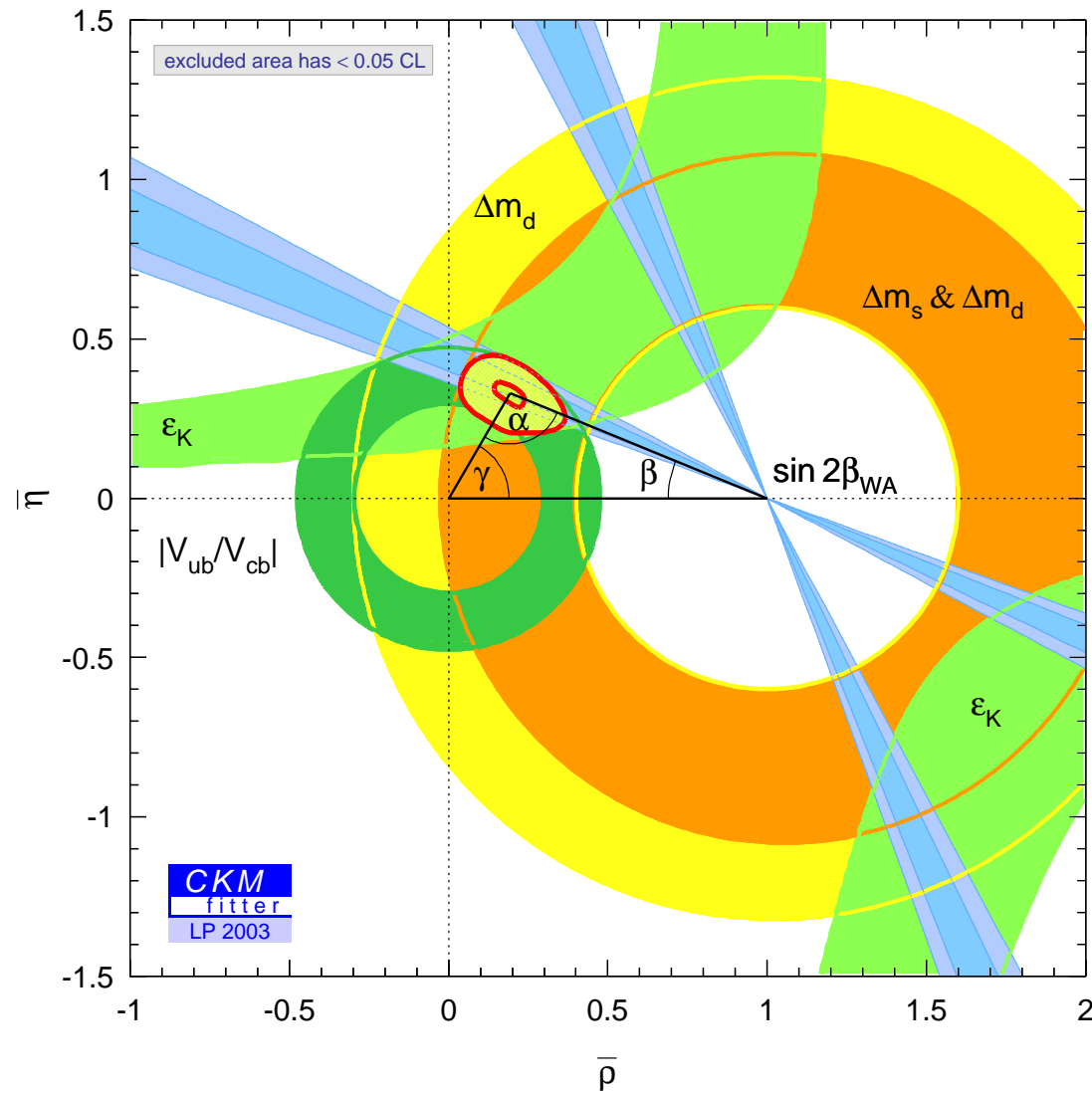

# CP Violation in the Standard Model

In the SM, CP violation is due to a complex phase in the CKM matrix:

$$V_{CKM} \simeq \begin{pmatrix} 1 - \frac{1}{2}\lambda^2 & \lambda & A\lambda^3(\rho - i\eta) \\ -\lambda(1 + iA^2\lambda^4\eta) & 1 - \frac{1}{2}\lambda^2 & A\lambda^2 \\ A\lambda^3(1 - \rho - i\eta) & -A\lambda^2 & 1 \end{pmatrix}$$

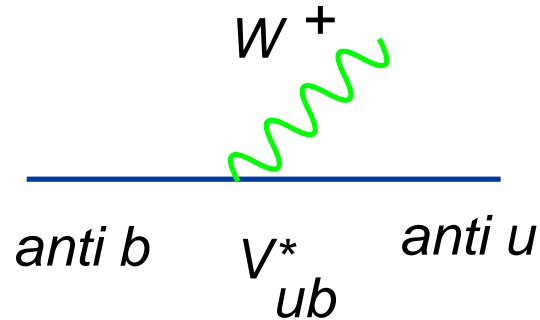
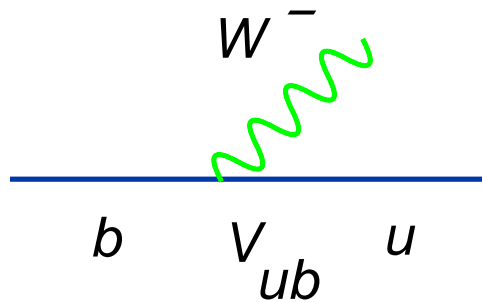

$$V_{ub} \neq V_{ub}^* \Rightarrow \text{CP Violation} \sim V_{ub} - V_{ub}^* = \text{Im}[V_{ub}] \sim \eta$$

SM: All CP violating effects  $\propto \eta$  ( only one complex phase )

$\Rightarrow$  CP violation in various processes are related

# CP Violation-Consequence

CP violation causes rate difference between process and anti process.

$$\mathcal{A}_f \equiv \frac{\Gamma(B \rightarrow f) - \Gamma(\bar{B} \rightarrow \bar{f})}{\Gamma(B \rightarrow f) + \Gamma(\bar{B} \rightarrow \bar{f})} \sim \sin \Phi \neq 0,$$

where  $\Phi$  is the CP violating weak phase

If you start with equal number of  $B$  and  $\bar{B}$  then CP violation ( $\mathcal{A}_f \neq 0$ ) will result at a later time unequal number of  $B$  and  $\bar{B}$  - unequal amount of matter and anti matter.

CP violation is a requirement to explain why the Universe is matter dominated though at the beginning(big bang) the universe was matter - antimatter symmetric.

However SM CP violation is not enough to explain the matter-antimatter asymmetry in the Universe. New Sources of CP violation are required. Where are they coming from?

# Standard Model: Summary

- The fundamental building blocks of matter are quarks and leptons. They interact through the strong (quarks, gluon), weak ( $W$ ,  $Z$ ) and the electromagnetic interactions (photon).
- Quarks are bound inside baryons and mesons, leptons can exist as free particles.
- Quarks and leptons come in six flavors and in three generations. Our present Universe is made of quarks and leptons of the first generation.
- Quarks and Leptons of the 2nd and 3rd generation decay to the first generation through weak interactions. There is CP violation in these decays.
- Quarks, Leptons,  $W$  and the  $Z$  particles get their masses by interacting with the Higgs particle.

# Standard Model: Problems

- Why are there three generations of quarks and leptons- are there more?
- Why only the top is heavy with  $m_t \sim m_W \sim m_Z$  and the other quarks and leptons are light.  
Why  $M_{III} > M_{II} > M_I$ . Why all masses are much smaller than the Planck Mass.
- Why is there mixing among generations- what is the origin of  $V_{CKM}$ ?
- What is the explanation of the matter-antimatter asymmetry of the Universe ?
- Why are the weak interactions different from the strong and EM interactions?
- All these puzzles suggest that the SM is not complete.

# Beyond the SM- New Physics

- Standard Model (SM) is not complete. The missing pieces have to be found- there must be new physics
- Two ways to search for new physics: First one is High Energy Experiments- Colliders
- Basic idea: SM is valid up to  $E \sim \text{TeV}$  and so at around TeV we should discover new particles
- New particles can be discovered at high energy colliders:  
e.g. : Tevatron- Chicago  
Large Hadron Collider (LHC)- being built at CERN

# Colliders: Tevatron at Fermilab



- Currently the highest energy particle collider in the world. The Tevatron accelerates protons and antiprotons in a 6.3 km ring to energies of up to 1 TeV.

# Colliders: Tevatron at Fermilab

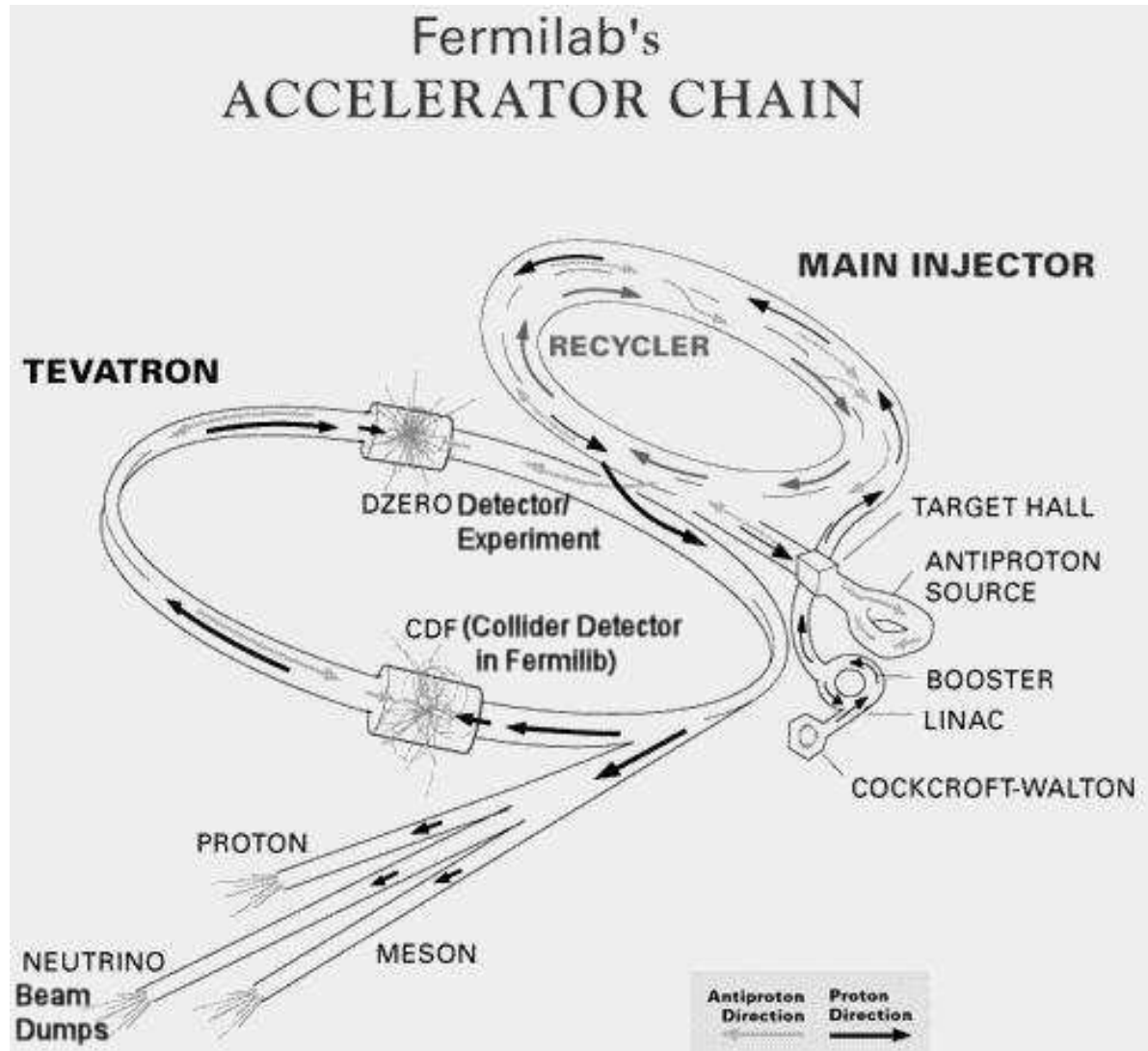

# Colliders:L(Large) H(Hadron) C(Collider)

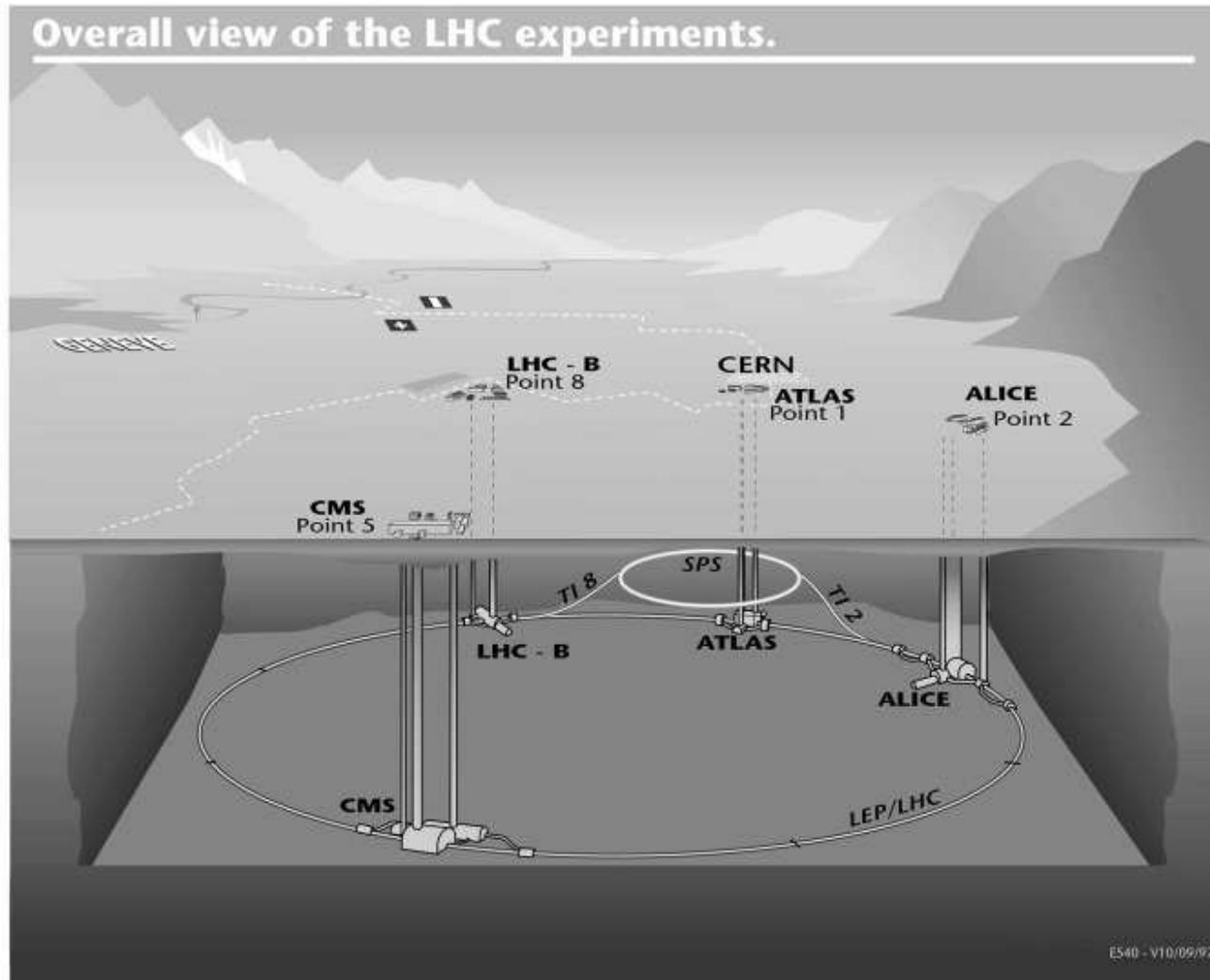

- Located at CERN, near Geneva, Switzerland. The collider is contained in a 27 kilometre (17 mi) circumference tunnel located underground at a depth ranging from 50 to 175 metres

# Colliders:L(Large) H(Hadron) C(Collider)

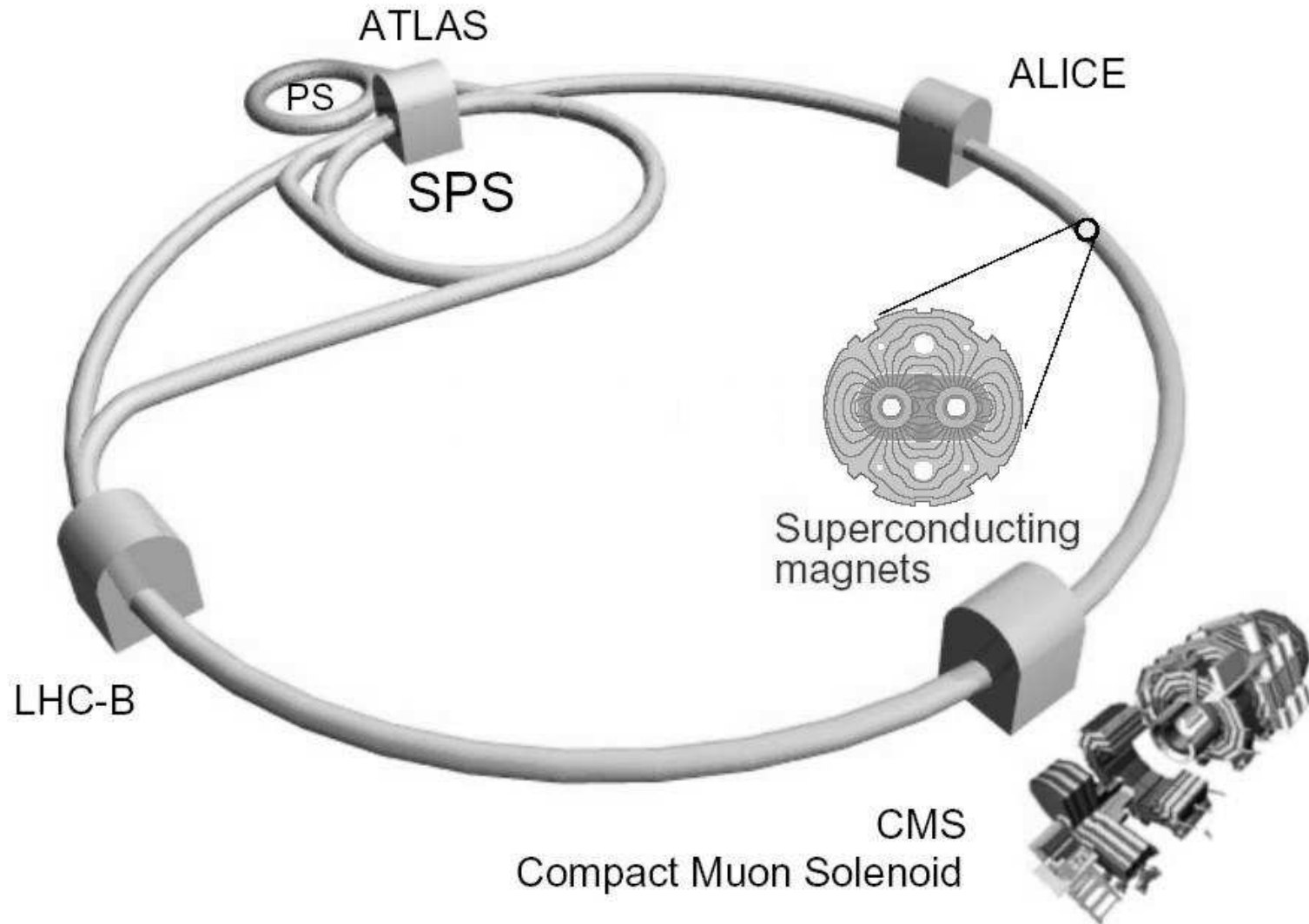

- The protons will each have an energy of 7 TeV, giving a total collision energy of 14 TeV.

# Beyond Standard Model-What?

- There are many models of New Physics- Supersymmetry (SUSY), Extra Dimensions, New strong force etc
- In SUSY for every boson there is a partner fermion and vice versa. Quarks have Squarks as partners, Leptons have Sleptons, photon has photino etc..
- Most New Physics models predict the existence of new particles
- The Tevatron and LHC are expected to produce these new particles.
- The discovery of the new particles will change our understanding of the Universe

# New Physics- SUSY ?

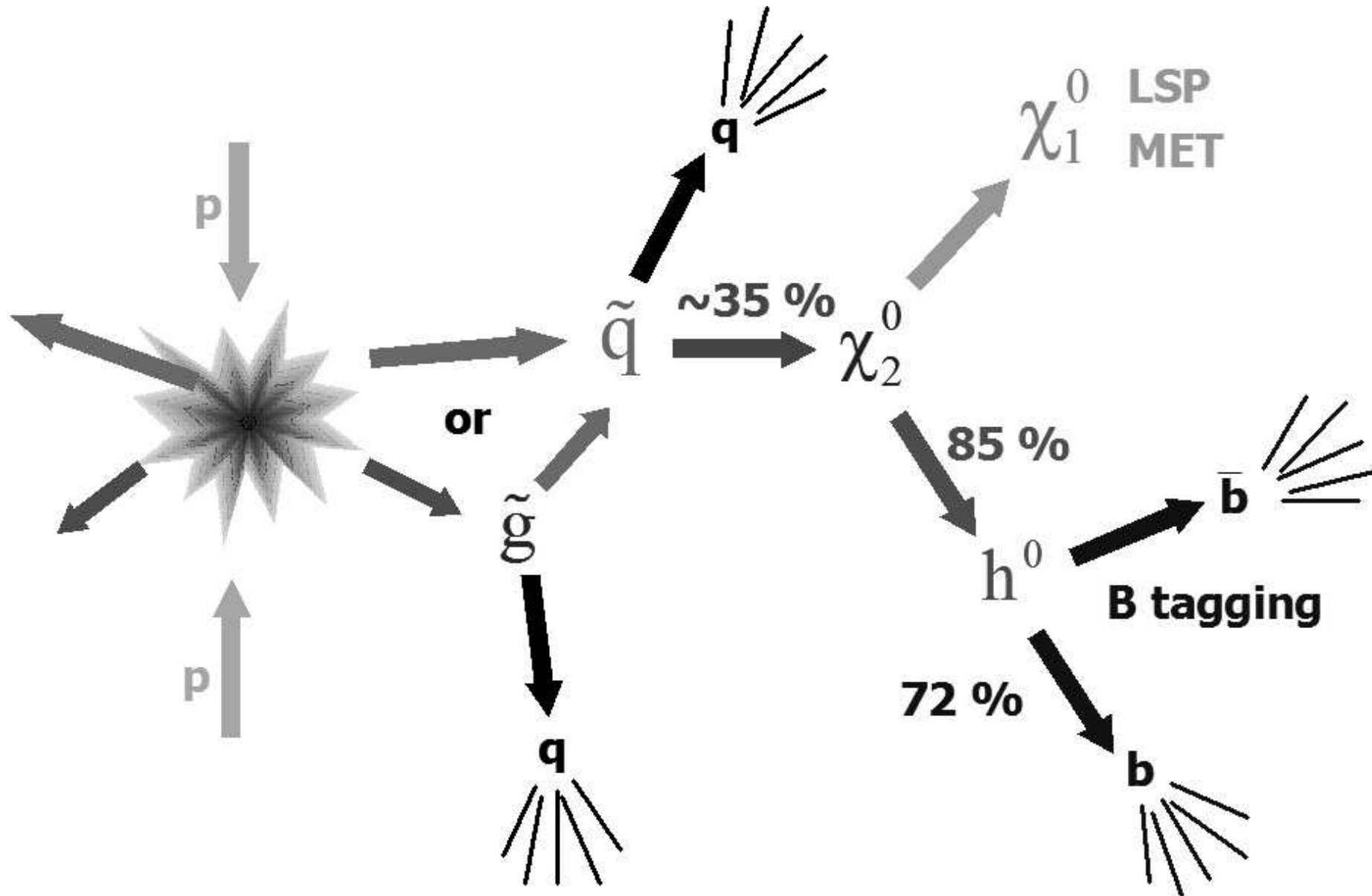

- Supersymmetry is a candidate for New Physics.

# Low Energy Experiments

- Discovery of new particles will yield only partial information about the correct model of new physics. Different high precision measurements are necessary to obtain additional information.
- Additional information about the new physics can be obtained via the virtual effects of new particles at low energies by making very precise experiments with high data sample.
- The precision experiments will help us pin down the correct model of New Physics.
- On going and planned experiments:  
BaBar, Belle- B factories  
BTeV, LHCb- near future  
Super B, Neutrino Factories- future
- Basic idea: Observe precisely deviations from the SM- observing new physics through small virtual effects

# Precision Machines

- Once new particles are discovered the question to ask is how do new particles interact- need precision machines.

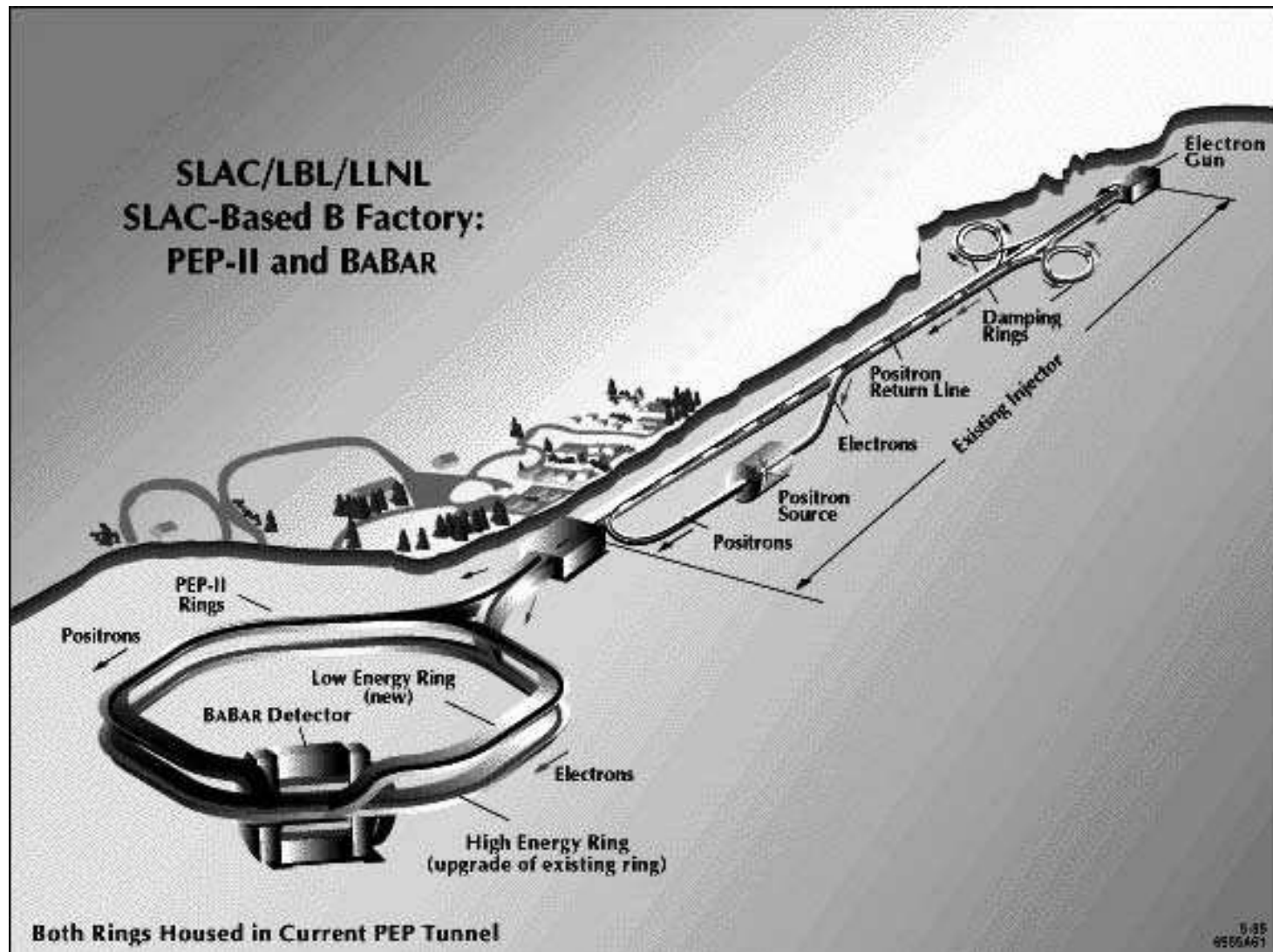

# Precision Machines

- Certain decays called Penguin Decays are very useful to study new particle interactions.

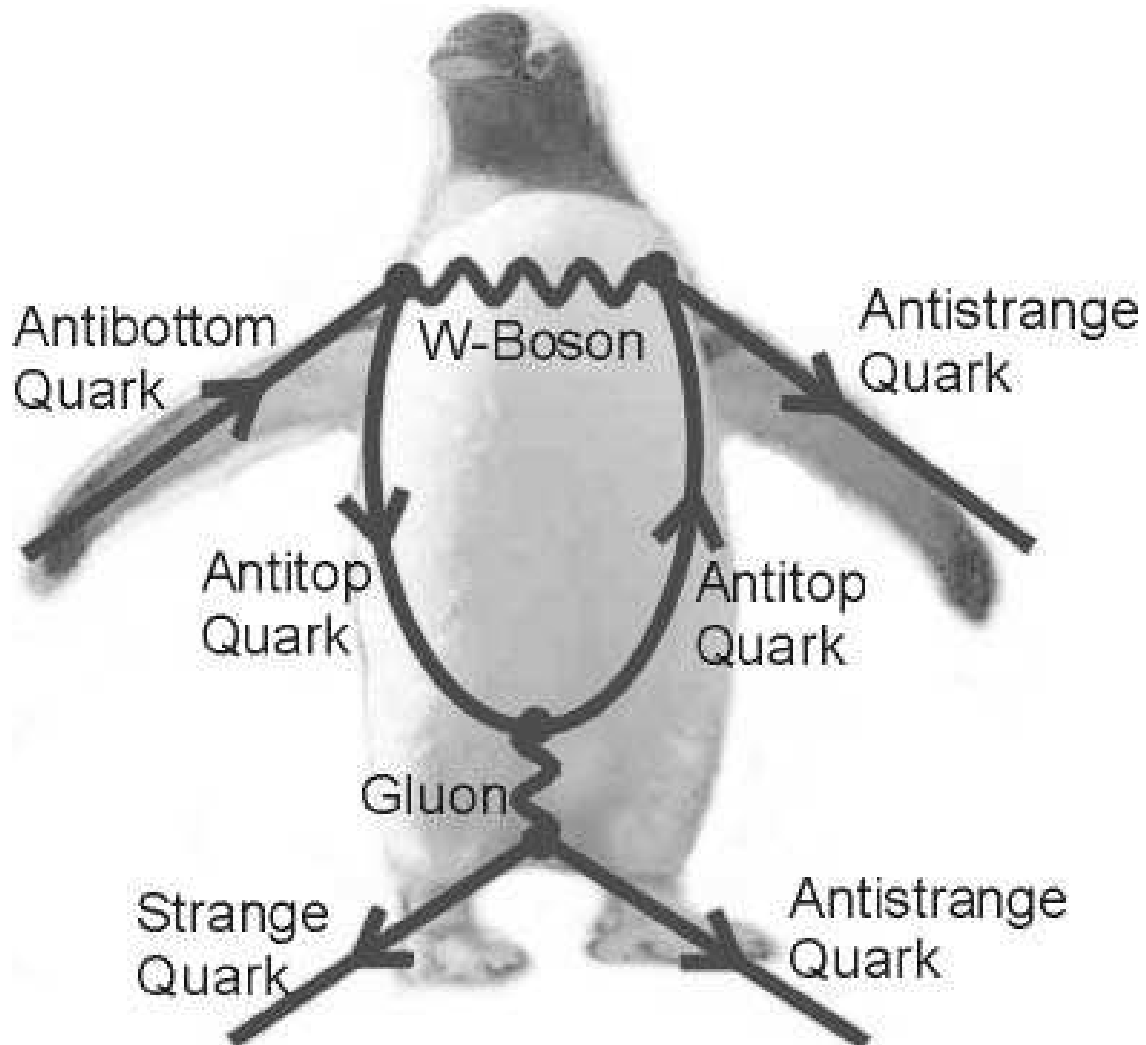

# Penguins in the SM

Program: In SM the Penguins are very rare and only arise as quantum corrections or Loops and are suppressed by small CKM elements E.g.  $B \rightarrow \phi K_s$  ( $b \rightarrow sg$ )

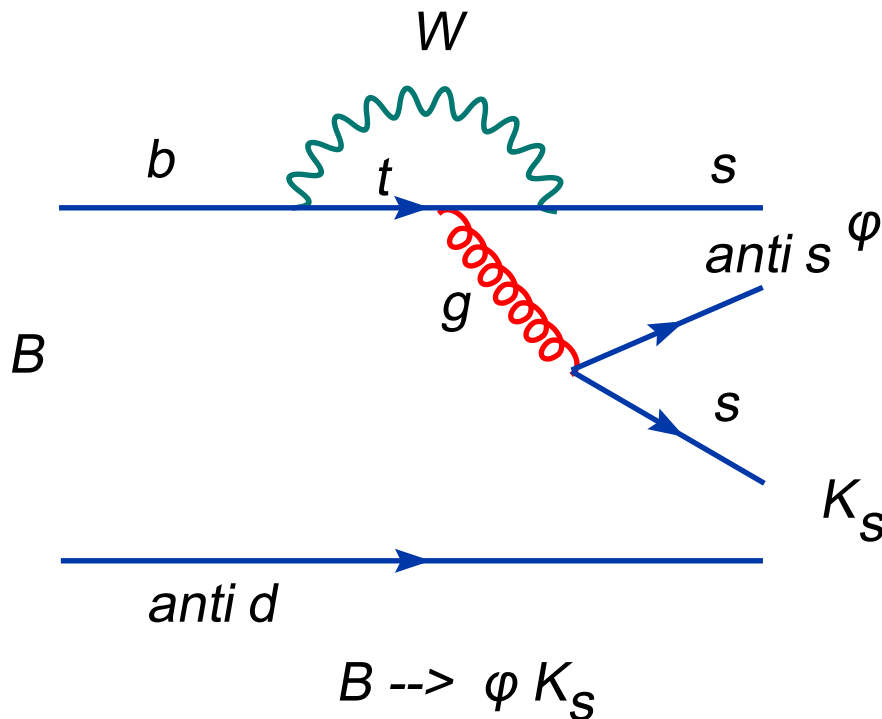

Beyond the SM these penguin processes( also called F(Flavor)C(Changing)N(Neutral)C(Current) processes ) can compete with the SM contribution, causing observable deviation from SM

# $B \rightarrow \phi K_S$ -NP models

- Many NP models can produce deviation from the SM for  $B \rightarrow \phi K_S$

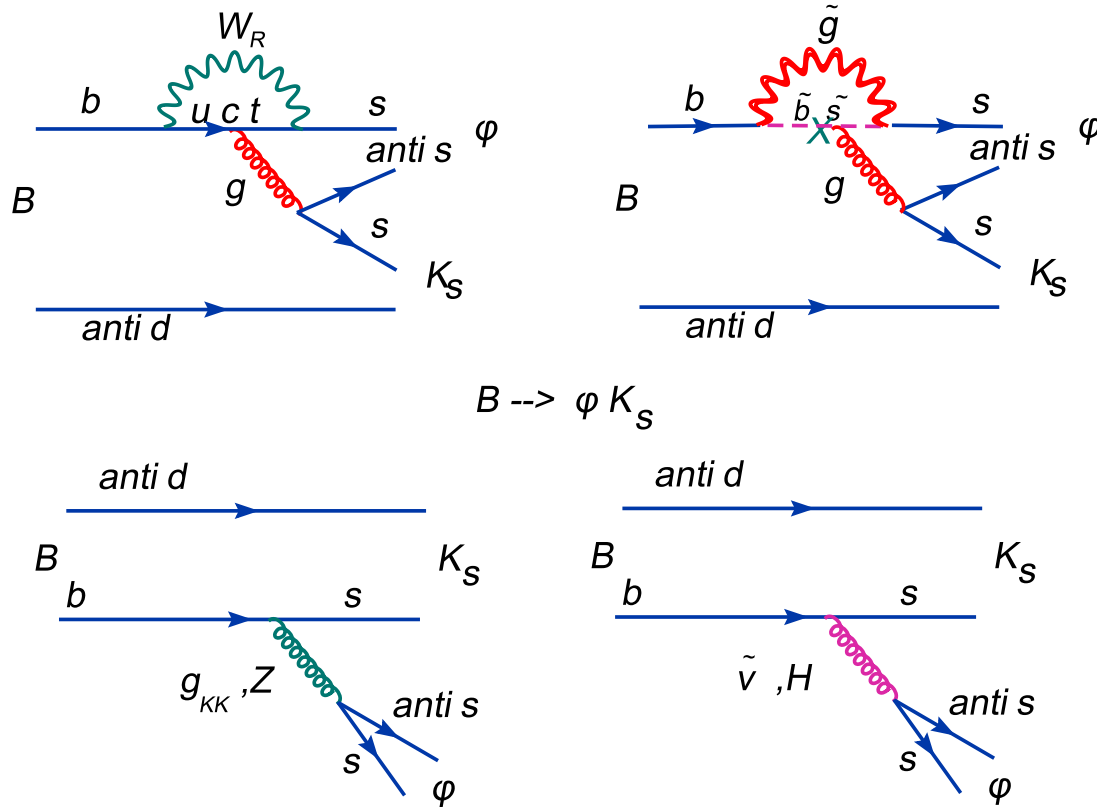

- By observing the nature of the deviation information about the correct new physics can be obtained.

# NP in B decays?

$$\sin(2\beta^{\text{eff}})/\sin(2\phi_1^{\text{eff}})$$

**HFAG**  
HEP 2005  
PRELIMINARY

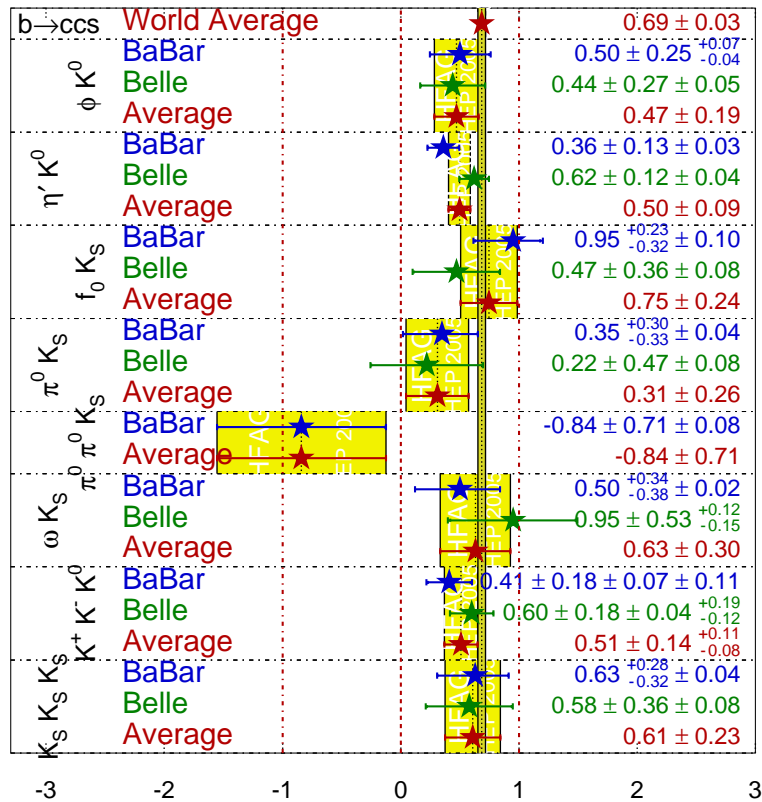

From precise measurements of the deviations we can find clues to the mathematical structure of the New physics.

# A new physics Model

- For some time now both BaBar and Belle have reported measurements that are not easy to understand in the SM- is it new physics?
- Not sure if it is just noise or a real signal. We will need a Super B factory to make a definite conclusion.
- Assuming there is new physics in these measurements one can construct a new physics model. This model contains an extra Higgs in addition to the SM higgs
- Many new physics models have extra Higgs but the production and decay rates of the new Higgs is different in different Models
- We are trying to see what are the signatures of our new physics model at LHC and how different it is from other new physics models( Godang and Datta)

# Conclusions

- Particle physics plays an important role in understanding our Universe.
- The Standard Model of Particle Physics can explain many aspects of our Universe but leaves many questions unanswered.
- The Standard Model is only approximately true- there must be New Physics that will resolve the SM puzzles.
- The physics community is involved in a vigorous search for this new physics at various experiments through out the world.